

PRODUCT: N FEMALE CRIMP, STRAIGHT, BULKHEAD, 50 OHM, FOR AIRCELL 5, LMR-200
PRODUCT CODE: E3704, Paratronic Oy

Description	Material	Note	General information	
Contact pin	Phosphor bronze	1	Dimensions in millimeters (mm), unless otherwise specified. RoHS compliant. Directive 2015/863 with exemption 6(c) Note, finish, plating thickness in micro-inches, μin (minimum): 1. Gold (3) over nickel (50) over copper (50) 2. Nickel (100) over copper (50) Max panel thickness: 6.5 mm Hex crimp size: Ferrule 5.41 mm / 0.213", pin 2.54 mm / 0.100" or solder IP67 when mated, IP40 unmated	Impedance 50 ohm Frequency range DC - 6 GHz VSWR 1.20 max Insertion loss ≤ 0.3 dB Insulator resistance ≥ 5 G Ω Resistance, center contact ≤ 1.5 m Ω , outer c. ≤ 0.25 m Ω Test voltage 2500 V rms, working voltage 1400 V rms Power handling ≤ 700 W @ 2 GHz
Insulators	PTFE	-		
Body	Brass	2		
Barrel	Brass	2		
Gasket	Silicone	-		
Nut, washer	Brass	2		
Ferrule	Copper	2		
Heat shrink	With glue	-		

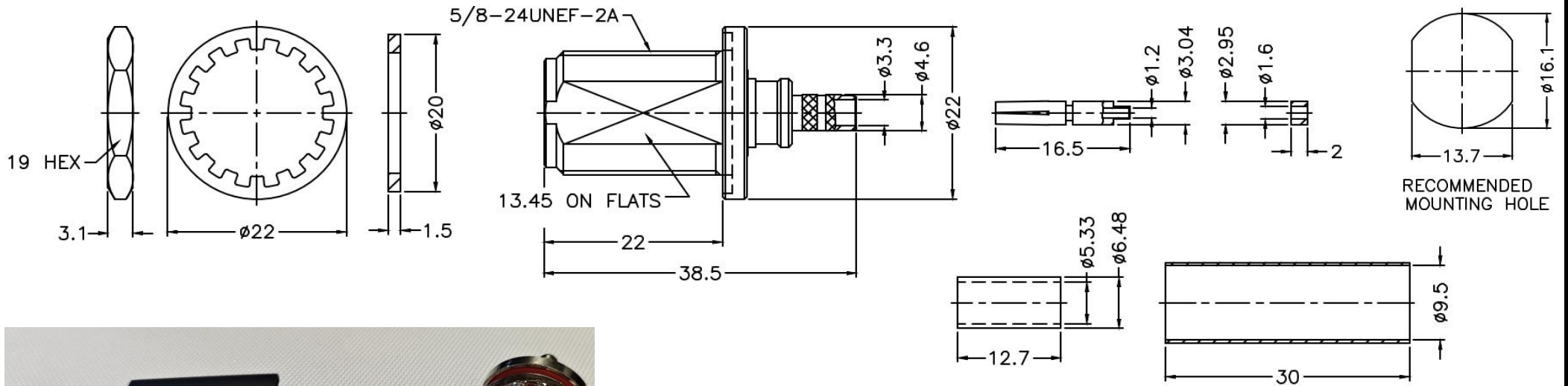

Cable stripping dimensions:

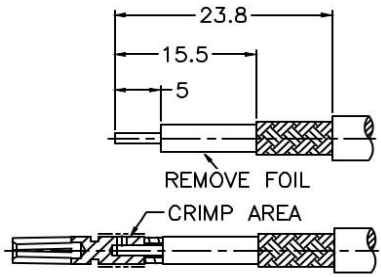

Title	Value
Drawing date	31.1.2023
Version	A
Website	www.paratronic.fi